

Fully coated CTMP board with coated reverse

Performa Alto is a coated GC1 board with a three-layer fibre construction and CTMP (chemi-thermomechanical pulp + chemical pulp) in the middle layer. It is double-pigment-coated on the top side, with one layer of coating on the reverse side.

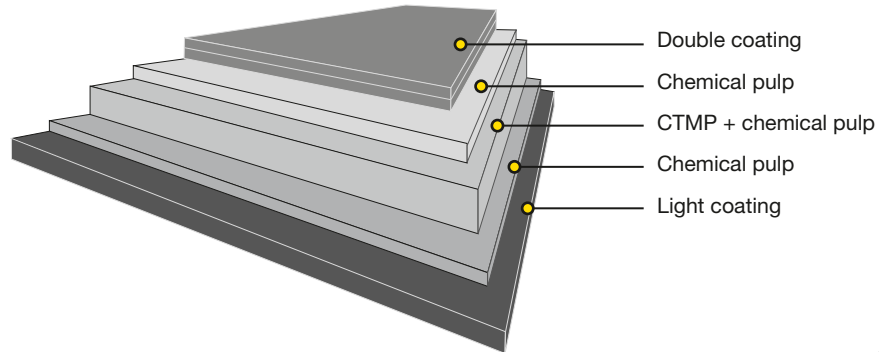

Issued: 12.2017
Cancels: 09.2013

Technical specification

Property / Unit	Tolerance									Standards
Grammage, g/m ²	±4%	200	220	240	260	280	300	325	350	ISO 536
Thickness, µm	±5%	260	290	330	365	400	430	470	515	ISO 534
Bending resistance L&W 15° MD, mN	-15%	121	182	241	316	400	484	592	699	ISO 2493
Bending resistance L&W 15° CD, mN	-15%	60	86	112	144	181	221	279	343	
Bending moment Taber 15° MD, mNm	-15%	6.0	8.8	11.6	15.3	19.3	23.4	28.6	33.8	
Bending moment Taber 15° CD, mNm	-15%	2.9	4.2	5.4	6.9	8.8	10.7	13.5	16.6	
Bending stiffness DIN 5° MD, mNm	-15%	10.3	15.5	20.5	26.9	34.0	41.1	50.3	59.4	
Bending stiffness DIN 5° CD, mNm	-15%	5.1	7.3	9.5	12.2	15.4	18.8	23.7	29.2	
Moisture, %		6.5	6.5	6.5	6.5	6.5	6.5	6.5	6.5	ISO 287
ISO Brightness C/2°, %, Top	min. 88	91.5	91.5	91.5	91.5	91.5	91.5	91.5	91.5	ISO 2470-1
ISO Brightness C/2°, %, Reverse	min. 85	88.5	88.5	88.5	88.5	88.5	88.5	88.5	88.5	
Brightness D65/10°, %, Top		98.5	98.5	98.5	98.5	98.5	98.5	98.5	98.5	ISO 2470-2
CIE Whiteness D65/10°, Top		118	118	118	118	118	118	118	118	ISO 11475
CIE Whiteness D65/10°, Reverse		108	108	108	108	108	108	108	108	
L*, Top		97	97	97	97	97	97	97	97	ISO 5631-2
a*, Top		2.0	2.0	2.0	2.0	2.0	2.0	2.0	2.0	
b*, Top		-6.3	-6.3	-6.3	-6.3	-6.3	-6.3	-6.3	-6.3	
Surface Smoothness, PPS 10, µm, Top	max. 1.7	1.0	1.0	1.0	1.0	1.0	1.0	1.0	1.0	ISO 8791-4
Surface Smoothness, PPS 10, µm, Reverse		4.0	4.0	4.0	4.0	4.0	4.0	4.0	4.0	
Surface Smoothness, Bendtsen, ml/min, Top		30	30	30	30	30	30	30	30	ISO 8791-2
Gloss 75, %		45	45	45	45	45	45	45	45	ISO 8254-1
Scott Bond, J/m ²	min. 120	200	200	200	200	200	200	200	200	TAPPI 569
Robinson chocolate test		<1 for one year storage in reels/pallets								EN 1230-2

All properties according to Imatra Mill measurements from board machine production.
Laboratory test climate 23°C/50% RH (According to ISO 187).
Tolerances based upon 95% confidence limits, apply to delivered reel/pallet average.
Bending moment Taber 15° and Bending resistance L&W 15° are binding, Bending stiffness DIN 5° are indicative.
Bending moment Taber 15° calculated from Bending resistance L&W 15°.

Fully coated CTMP board with coated reverse

Certificates

Quality management ISO 9001
 Environmental management ISO 14001
 Product safety ISO 22000
 Health and safety OHSAS 18001
 Energy management ISO 50001
 EU Ecolabel registration SE/011/006, the ecological criteria for Copying and Graphic Paper 2011/333/EY, L149/12, 8.6.2011



FSC and PEFC certified board available upon request.

The EU Ecolabel confirms that the board fulfils the European Commission's ecological criteria for copying and graphic paper and is therefore only available for graphical end uses.

EU Ecolabel available upon request on graphical end uses.



Paperboard is recyclable

Key characteristics and main enduses

Performa Alto is a high-quality coated board designed to guarantee impressive graphics and performance in tough converting processes. It is typically used for cosmetics and perfumes, pharmaceuticals and healthcare packaging and for various graphical applications. Performa Alto features a blade-coated top side that gives excellent print results, and the reverse side is also suitable for full-colour printing. Thanks in part to chemical pulp in the middle layer, the board offers excellent strength and converting properties

Printing and finishing techniques

The product can be used with different printing techniques such as offset, flexo and digital printing. In digital printing, the product is suitable for several different sheet- or web-fed presses. Dry or liquid toner technology can be used, although in some cases, pretreatment of the substrate might be required. The latest certification status can be verified on the press manufacturer's website or with local Stora Enso representatives. It is important to check the limitations of the equipment, particularly because of the exceptional difference in the thickness and stiffness of board compared with paper in the same grammages. When running thicker substrates, the press manufacturer's recommendations should be referred to for optimal grain direction. Essentially all of the same finishing processes apply to both digitally printed and offset printed work. Since a wide variety of digital printing equipment is available in the market, it is important that a new commercial print job is always preceded by a trial run, including all required printing and converting process phases.

The product works very well with different finishing techniques, such as embossing, hot foil stamping and others. It is suitable for laser coding. Certificates according to PTS-DF 105/2013 and PTS-DF 103/2011 are available upon request.

Storage recommendations

For optimal printing results, the moisture proof wrapping should not be removed until the board has reached the temperature of the press room.

Pallet/Reel Weight (kg)	Difference in temperature between board and press room (press room temp. approx. 20°C)		
	10°C	20°C	30°C
400 kg	2 days	2 days	3 days
800 kg	2 days	3 days	4 days
1200 kg	2 days	4 days	5 days

The product properties, according to the specifications, are guaranteed for 12 months after the production date. In order to ensure product safety, the product must be well wrapped and stored in its original cover indoors, sheltered from rain and snow. The recommended storage conditions are 50-55% relative humidity and 20-23°C.

